



Instruction Sheet

Greens King IV™ TrueSet™ Reels

62841 – 22 in. Left Hand 7 Blade TrueSet™ Reel

62842 – 22 in. Right Hand 7 Blade TrueSet™ Reel

62843 – 22 in. Left Hand 9 Blade TrueSet™ Reel

62844 – 22 in. Right Hand 9 Blade TrueSet™ Reel

62845 – 22 in. Left Hand 11 Blade TrueSet™ Reel

62846 – 22 in. Right Hand 11 Blade TrueSet™ Reel

62847 – 22 in. Left Hand 15 Blade TrueSet™ Reel

62848 – 22 in. Right Hand 15 Blade TrueSet™ Reel

 **WARNING**

If incorrectly used, this machine can cause severe injury. Those who use and maintain this machine should be trained in its proper use, warned of its dangers and should read the entire manual before attempting to set up, operate, adjust, or service the machine.

FOREWORD

This manual contains adjustment, maintenance, troubleshooting instructions, and parts list for your new Jacobsen reel. This manual should be stored with the mower for reference during operation.

Before you operate your mower, you and each operator you employ should read the manual carefully in its entirety. By following the safety, operating, and maintenance instructions, you will prolong the life of your mower and maintain its maximum efficiency.

If additional information is needed, contact your Jacobsen Dealer.

The serial plate is attached to the reel frame. Jacobsen recommends you record these numbers below for easy reference.

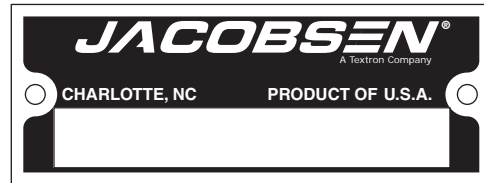

Suggested Stocking Guide

To keep your mower fully operational and productive, Jacobsen suggests you maintain a stock of the more commonly used maintenance items. We have included part numbers for additional support materials and training aids.

To order any of the following material:

1. Write your full name and complete address on your order form.
2. Explain where and how to make shipment:
 - UPS
 - Regular Mail
 - Overnight
 - 2nd Day

3. Order by the quantity desired, the part number, and the description of the part.
4. Send or bring the order to your authorized Jacobsen Dealer.

Service Parts

Qty.	Part No.	Description	Qty.	Part No.	Description
	4252470	Bedknife Screw (100 Pack)			
	460008	Cotter Pin, 5/64 x 3/4"			

Service Support Material

Qty.	Part No.	Description
	4269792	5 in. Reel Technical Repair Manual

These are the original instructions verified by Jacobsen, A Textron Company.

© 2012, Jacobsen, A Textron Company/Textron Innovations Inc.
 "All rights reserved, including the right to reproduce this material or portions thereof in any form."

Proposition 65 Warning

This product contains or emits chemicals known to the State of California to cause cancer and birth defects or other reproductive harm.

Table of Contents

1	Safety	
1.1	Operating Safety.....	4
1.2	Important Safety Notes	5
2	Specifications	
2.1	Product Identification	6
2.2	Cutting Units	6
2.3	Accessories & Support Literature	6
2.4	Declaration of Incorporation	7
3	Setup	
3.1	Front Roller and Accessories	9
3.2	Reel Motor	9
3.3	Torsion Springs	9
3.4	Anti-Sway Springs	9
4	Adjustments	
4.1	General.....	10
4.2	Bedknife-To-Reel	10
4.3	Bedknife Adjustment	11
4.4	Cutting Height	11
4.5	Reel Bearing	12
4.6	Bedknife Adjuster Spring	12
4.7	Bedknife Adjuster Tension	12
4.8	Grinding Bedknife	12
4.9	Antisway Spring	13
4.10	Leveling Procedure	13
4.11	Torque Specification	14
5	Notes	

1 SAFETY

1.1 OPERATING SAFETY



WARNING

EQUIPMENT OPERATED IMPROPERLY OR BY UNTRAINED PERSONNEL CAN BE DANGEROUS.

Familiarize yourself with the location and proper use of all controls. Inexperienced operators should receive instruction from someone familiar with the equipment before being allowed to operate the machine.

1. Safety is dependent upon the awareness, concern and prudence of those who operate or service the equipment. Never allow minors to operate any equipment.
2. It is your responsibility to read this manual and all publications associated with this equipment (Safety & Operation Manual, Engine Manual, and attachments/accessories instruction sheets). If the operator cannot read English it is the owner's responsibility to explain the material contained in this manual to them.
3. Learn the proper use of the machine, the location and purpose of all the controls and gauges before you operate the equipment. Working with unfamiliar equipment can lead to accidents.
4. Never allow anyone to operate or service the machine or its attachments without proper training and instructions; or while under the influence of alcohol or drugs.
5. Wear all the necessary protective clothing and personal safety devices to protect your head, eyes, ears, hands, and feet. Operate the machine only in daylight or in good artificial light.
6. Evaluate the terrain to determine what accessories and attachments are needed to properly and safely perform the job. Only use accessories and attachments approved by Jacobsen.
7. Stay alert for holes in the terrain and other hidden hazards.
8. Inspect the area where the equipment will be used. Pick up all the debris you can find before operating. Beware of overhead obstructions (low tree limbs, electrical wires, etc.) and also underground obstacles (sprinklers, pipes, tree roots, etc.). Enter a new area cautiously. Stay alert for hidden hazards.
9. Never direct discharge of material toward bystanders, nor allow anyone near the machine while in operation. The owner/operator can prevent and is responsible for injuries inflicted to themselves, to bystanders, and damage to property.
10. Do not carry passengers. Keep bystanders and pets a safe distance away.
11. Never operate equipment that is not in perfect working order or is without decals, guards, shields, discharge deflectors, or other protective devices securely fastened in place.
12. Never disconnect or bypass any switch.
13. Do not change the engine governor setting or overspeed the engine.
14. Carbon monoxide in the exhaust fumes can be fatal when inhaled. Never operate the engine without proper ventilation or in an enclosed area.
15. Fuel is highly flammable; handle with care.
16. Keep the engine clean. Allow the engine to cool before storing and always remove the ignition key.
17. Disengage all drives and engage parking brake before starting the engine (motor). Start the engine only when sitting in operator's seat, never while standing beside the unit.
18. Equipment must comply with the latest federal, state, and local requirements when driven or transported on public roads. Watch out for traffic when crossing or operating on or near roads.
19. Local regulations may restrict the age of the operator.
20. Never use your hands to search for oil leaks. Hydraulic fluid under pressure can penetrate the skin and cause serious injury.
21. Operate the machine up and down the face of slopes (vertically), not across the face (horizontally).
22. To prevent tipping or loss of control, do not start or stop suddenly on slopes. Reduce speed when making sharp turns. Use caution when changing directions.
23. Always use the seat belt when operating mowers equipped with a Roll Over Protective Structure (ROPS).
Never use a seat belt when operating mowers without a ROPS.
24. Always disconnect battery cables from battery before performing any welding operation on the mower.

This machine is to be operated and maintained as specified in this manual and is intended for the professional maintenance of specialized turf grasses. It is not intended for use on rough terrain or long grasses.

1.2 IMPORTANT SAFETY NOTES



This safety alert symbol is used to alert you to potential hazards.

DANGER - Indicates an imminently hazardous situation which, if not avoided, **WILL** result in death or serious injury.

WARNING - Indicates a potentially hazardous situation which, if not avoided, **COULD** result in death or serious injury.

CAUTION - Indicates a potentially hazardous situation which, if not avoided, **MAY** result in minor or moderate injury and property damage. It may also be used to alert against unsafe practices.

NOTICE - Indicates a potentially hazardous situation which, if not avoided, **MAY** result in property damage. It may also be used to alert against unsafe practices.

For pictorial clarity, some illustrations in this manual may show shields, guards or plates open, or removed. Under no circumstances should this equipment be operated without these devices securely fastened in place.



WARNING

The Interlock System on this mower prevents the mower from starting unless the parking brake is engaged, reel levers are off, and traction lever is in Neutral. The system will stop the engine if the operator leaves the seat without engaging the parking brake, setting the reel levers to off, and placing traction lever in Neutral.

NEVER operate mower unless the Interlock System is working.



WARNING

1. Before leaving the operator's position for any reason:
 - a. Return traction lever to Neutral.
 - b. Disengage all drives.
 - c. Lower all implements to the ground.
 - d. Engage parking brake.
 - e. Stop engine and remove the ignition key.
2. Keep hands, feet, and clothing away from moving parts. Wait for all movement to stop before you clean, adjust, or service the machine.
3. Keep the area of operation clear of all bystanders and pets.
4. Never carry passengers.

By following all instructions in this manual, you will prolong the life of your machine and maintain its maximum efficiency. Adjustments and maintenance should always be performed by a qualified technician.

If additional information or service is needed, contact your Authorized Jacobsen Dealer who is kept informed of the latest methods to service this equipment and can provide prompt and efficient service.

2 SPECIFICATIONS

2.1 PRODUCT IDENTIFICATION

62841	Greens King IV™ Left Hand 22 in. (559 mm), 11 Blade Reel, without front roller.
62842	Greens King IV™ Right Hand 22 in. (559 mm), 11 Blade Reel, without front roller.
62843	Greens King IV™ Left Hand 22 in. (559 mm), 11 Blade Reel, without front roller.
62844	Greens King IV™ Right Hand 22 in. (559 mm), 11 Blade Reel, without front roller.
62845	Greens King IV™ Left Hand 22 in. (559 mm), 11 Blade Reel, without front roller.
62846	Greens King IV™ Right Hand 22 in. (559 mm), 11 Blade Reel, without front roller.

62847	Greens King IV™ Left Hand 22 in. (559 mm), 15 Blade Reel, without front roller.
62847	Greens King IV™ Right Hand 22 in. (559 mm), 15 Blade Reel, without front roller.
Serial Number	An identification plate, like the one shown, listing the serial number, is attached to the frame of the reel.

Always provide the serial number of the unit when ordering replacement parts or requesting service information.



2.2 CUTTING UNITS

Reel Diameter	5 in. (127 mm)
22 in. Blade Options	7, 9, 11, or 15 blades
Height of Cut Range	1/16 to 7/16 in. (1.6 to 11.1 mm)

Cutting Frequency	
7 Blade	0.083 in./mph (1.314 mm/kph)
9 Blade	0.064 in./mph (1.010 mm/kph)
11 Blade	0.053 in./mph (0.836 mm/kph)
15 Blade	0.039 in./mph (0.613 mm/kph)

2.3 ACCESSORIES & SUPPORT LITERATURE

Contact your area Jacobsen Dealer for a complete listing of accessories and attachments.

CAUTION

Use of other than Jacobsen authorized parts and accessories may cause personal injury or damage to the equipment.

Accessories

Orange Touch-up Paint (12 oz. spray)	554598
Rear Roller Cleaner	62820
Turf Groomer Left Hand 1/4" Spacing	67911
Turf Groomer Right Hand 1/4" Spacing	67912
Turf Groomer Left Hand 1/2" Spacing	67913
Turf Groomer Right Hand 1/2" Spacing	67914
High Cut Roller Kit (15/16")	68634

Magknife Kit

22 in. Medium Section Magknife Kit	4266571
22 in. Tournament Magknife Kit	4266551
22 in. Super Tournament Magknife Kit	4266570

Solid Rollers

22 in. with Scraper (Light)	68530
22 in. with Scraper	68641
22 in. Solid Tube Rear Roller	1004990

Grooved Rollers

22 in. Assembled Disc	68527
22 in. Machined Aluminum	68614
22 in. Machined Steel	68613
22 in. Segmented Roller	68673

Support Literature

Technical Repair Manual	4269792
-------------------------	---------

2.4 DECLARATION OF INCORPORATION

DECLARATION OF INCORPORATION • ДЕКЛАРАЦИЯ ЗА ОБЕДИНЕНИЕ • PROHLÁŠENÍ O ZALOŽENÍ SPOLEČNOSTI • INKORPORERINGSERKLÆRING • INCORPORATIEVERKLARING • KINNITUS ÜHENDAMISE KOHTA • ASENNUSTODISTUS • DECLARATION D'INCORPORATION • EINBAUBESCHEINIGUNG • ΔΗΛΩΣΗ ΜΗ ΣΥΜΜΟΡΦΩΣΗΣ • ΒΕΒΪΡΤΪΣΙ ΝΥΙΛΑΤΚΟΖΑΤ • DICHIARAZIONE DI INCORPORAZIONE • NOFORMĚŠANAS DEKLARÁCIJA • PRIJUNGIMO DEKLARACIJA • DIKJARAZZJONI
TA' INKORPORAZZJONI • DEKLARACIJA ZGODOŃCI DLA PODZESPOŁU • DECLARAÇÃO DE INCORPORAÇÃO • DECLARAȚIE DE ÎNCORPORARE • VYHLÁSENIE O ZABUDOVANÍ SÚČASTI • IZJAVA ZA VGRADNJO • DECLARACIÓN DE INCORPORACIÓN • INBYGGNADSDEKLARATION

Business name and full address of the manufacturer • Търговско име и пълен адрес на производителя • Obchodní jméno a plná adresa výrobce • Producentens firmanavn og fulde adresse • Bedrijfsnaam en volledig adres van de fabrikant • Tootja ärinimi ja täielik address • Valmistajan toiminimi ja täydellinen osoite • Nom commercial et adresse complète du fabricant • Firmenname und vollständige Adresse des Herstellers • Εταιρεία και τηλέφωνο και διεύθυνση κατασκευαστή • A gyártó üzleti neve és teljes címe • Ragione sociale e indirizzo completo del fabbricante • Uzņēmuma nosaukums un pilna ražotāja adrese • Verslo pavadinimas ir pilnas gamintojo adresas • Isem kummerçjali u indirizz sħih tal-fabbrikant • Nazwa firmy i pełny adres producenta • Nome da empresa e endereço completo do fabricante • Denumirea comercială și adresa completă a producătorului • Obchodný názov a úplná adresa výrobcu • Naziv podjetja in polni naslov proizvajalca • Nombre de la empresa y dirección completa del fabricante • Tillverkarens företagsnamn och kompletta adress	Jacobsen, A Textron Company 11524 Wilmar Blvd. Charlotte, NC 28273, USA
--	---

Description and identification of the partly completed machinery. • Описание и идентификация на частично завършените машини. • Popis a identifikace částečně dokončeného strojního zařízení. • Beskrivelse og identifikation af den delvist fremstillede maskine. • Beschrijving en identificatie van de gedeeltelijk voltooidde machine. • Osaliselt komplekteeritud masina kirjeldus ja määratlus. • Osittain kootun laitteiston kuvaus ja määrittely. • Description et identification de la quasi-machine. • Bezeichnung und Identifizierung der teilgefertigten Vorrichtung • Περιγραφή και προσδιορισμός ημιτελούς μηχανήματος. • A részlegesen megépített gép leírása és meghatározása. • Descrizione e identificazione della quasi-macchina • Da lèji pabeigtas iekārtas apraksts un identifikācija. • Περιγραφή και προσδιορισμός ημιτελούς μηχανήματος. • Deskrizzjoni u identifikazzjoni tal-makkinarju li jkun lest parzjalment. • Opis i oznaczenie częściowo ukończonego urządzenia • Descrição e identificação do equipamento parcial. • Descrierea și identificarea echipamentului finalizat parțial • Opis a identifikácia podzostavy strojného zariadenia • Opis in identifikacija delno dokončanega stroja. • Descripción e identificación de la maquinaria parcialmente completada. • Beskrivning och identifiering av maskindelarna.

Product Code	Serial Number	Description
62841	6284101651 ~ 6284102999	Greens King IV Left Hand 22 in. (559 mm) 7 Blade TrueSet™ Reel
62842	6284201651 ~ 6284202999	Greens King IV Right Hand 22 in. (559 mm) 7 Blade TrueSet™ Reel
62843	6284301651 ~ 6284302999	Greens King IV Left Hand 22 in. (559 mm) 9 Blade TrueSet™ Reel
62844	6284401651 ~ 6284402999	Greens King IV Right Hand 22 in. (559 mm) 9 Blade TrueSet™ Reel
62845	6284501651 ~ 6284502999	Greens King IV Left Hand 22 in. (559 mm) 11 Blade TrueSet™ Reel
62846	6284601651 ~ 6284602999	Greens King IV Right Hand 22 in. (559 mm) 11 Blade TrueSet™ Reel
62847	6284701651 ~ 6284702999	Greens King IV Left Hand 22 in. (559 mm) 15 Blade TrueSet™ Reel
62848	6284801651 ~ 6284802999	Greens King IV Right Hand 22 in. (559 mm) 15 Blade TrueSet™ Reel

We undertake to transmit, in response to a reasoned request by the national authorities, relevant information on the partly completed machinery. This shall be by hardcopy and shall be without prejudice to the intellectual property rights of the manufacturer of the partly completed machinery.

Ние обещаваме да предадем, в отговор на основателно искане от националните органи, съответна информация за частично завършените машини. Това ще се осъществи чрез документ и няма да бъде в нарушение на правата за интелектуална собственост на производителя на частично завършените машини.

Zavazujemo se na základě zdůvodněné žádosti ze strany národních úřadů poskytnout příslušné informace o částečně dokončeném strojním zařízení. Informace budou předány v tištěné podobě a nepoškodí práva k duševnímu vlastnictví výrobce týkající se částečně dokončeného strojního zařízení.

Som svar på en begründet anmodning fra de nationale myndigheder forpligter vi os til at videregive oplysninger om den delvist fremstillede maskine. Dette bliver gjort i papirudgave og med forbehold for de immaterielle rettigheder, som indehaves af producenten af den delvist fremstillede maskine.

We zijn van plan, in reactie op een redelijk verzoek van de nationale autoriteiten, relevante informatie over de gedeeltelijk voltooidde machine te verzenden. Dit wordt gedaan in de vorm van fysieke kopieën en deze kopieën zullen onder alle voorbehoud behoren tot de intellectuele eigendomsrechten van de fabrikant van de gedeeltelijk voltooidde machine.

Me kohustume riigiseste asutuste põhjendatud nõudmisel edastama asjakohast teavet osaliselt komplekteeritud masina kohta. Andmed edastatakse paberkanalil ning sellega ei tohi piirata osaliselt komplekteeritud masina tootja õigusi intellektuaalsele omandile.

Stoudumme toimitamaan osittain koottua laitteistoa koskevat olennaiset tiedot vastineena kansallisten viranomaisten perusteltuun pyyntöön. Tiedot toimitetaan paperilusteena. Ne eivät rajoita valmistajan osittain koottua laitteistoa koskevia immateriaalioikeuksia.

Nous nous engageons à fournir, en réponse à une demande rationnelle des autorités nationales, toute information appropriée concernant la quasi-machine. Ceci se fera par copie papier et sans préjudger des droits de propriété intellectuelle du fabricant de la quasi-machine.

Wir verpflichten uns, auf eine begründete Aufforderung durch die nationalen Behörden hin, relevante Informationen über die teilgefertigte Maschine zu übersenden. Diese werden als Ausdruck übersandt und dürfen sich nicht nachteilig auf die Rechte am geistigen Eigentum des Herstellers der teilgefertigten Maschine auswirken.

Αναλαμβάνουμε να μεταβιβάσουμε, προς απάντηση εύλογής αίτησης των εθνικών αρχών, τις σχετικές πληροφορίες όσον αφορά το ημιτελές μηχανήμα. Αυτό θα πρέπει να γίνει γραπτώς και δίχως να θίγει τα πνευματικά δικαιώματα του κατασκευαστή του ημιτελούς μηχανήματος.

Vállaljuk, hogy átadjuk – a nemzeti hatóságok megalapozott kérésére válaszul – a részlegesen megépített gépre vonatkozó információkat. Az információkat nyomtatott példányban adjuk át. A nyomtatott példány átadása a részlegesen megépített gép gyártójának szellemi tulajdonjogaira tett kötelezettség nélkül történik.

Ci impegniamo a trasmettere, in risposta ad una richiesta adeguatamente motivata delle autorità nazionali, informazioni pertinenti sulla quasi-macchina. L'impegno sarà redatto in forma cartacea e lascerà impregiudicati i diritti di proprietà intellettuale del fabbricante della quasi-macchina.

Atsaucoties uz pamatotu valsts iestāžu pieprasījumu, mēs apņemamies nodot saisto informāciju par daļēji pabeigtu iekārtu. Tā būs cietā kopija un neradīs kaitējumu daļēji pabeigtās iekārtas ražotāja intelektuālā īpašuma tiesībām.

Atsakydami į nacionalinių valdžios organų užklausą, pateikiame informaciją apie dalinai užbaigtus mechanizmus. Šis dokumentas yra atspausdintas elektroninio originalo variantas ir be jokio išankstinio susitarimo neturi tikslo pažeisti dalinai užbaigto mechanizmo gamintojo intelektualines nuosavybės teisių.

Ahna nwieghdu li nipprezentaw, meta mitlubin mill-awtoritajiet nazzjonali, l-informazzjoni rilevanti dwar il-makkinarju li jkun lest parzjalment. Din l-informazzjoni ghandha tkun f'forma stampata u minghajr preġudizzju għad-drittijiet tal-proprjetà intelletwali tal-fabbrikant tal-makkinarju li jkun lest parzjalment.

Na zasadańcioną prośbę instytucji państwowych zobowiązujemy się do przekazania wszelkich informacji na temat częściowo ukończonego urządzenia. Będą one przekazane na piśmie. Strona przekazująca w/wym. dokumentację nie będzie rościła sobie żadnych praw do własności intelektualnej producenta częściowo ukończonego urządzenia.

Na sequência de pedido razoável por parte das autoridades nacionais, comprometemo-nos a transmitir informações importantes sobre o equipamento parcial. Tal será feito por meio de hardcopy e sem prejuízo para os direitos de propriedade intelectual do fabricante do equipamento parcial.

Ne angajăm să transmitem, ca răspuns la o solicitare motivată a autorităților naționale, informații relevante privind echipamentul finalizat parțial. Această se va efectua în format hârtie și fără a aduce atingere drepturilor de proprietate intelectuală ale producătorului echipamentului finalizat parțial.

Zavazujemo sa, že na základě odůvodněné požadavky národních orgánů předložíme důležité informace o podzostave strojného zariadenia. Musí to být v tištěné formě a bez újmy na práвах duševného vlastníctva výrobcu podzostavy strojného zariadenia.

Zavežujemo se, da bomo na utemeljeno zahtevo nacionalnih organov predložili zadene informacije o delno dokončanem stroju. Informacije bodo v tiskani obliki in ne bodo posegale v pravice intelektualne lastnine proizvajalca delno dokončanega stroja. Nos comprometemos a transmitir, en respuesta a una petición razonada por parte de las autoridades nacionales, información relevante sobre la maquinaria parcialmente completada. Esta será transmitida en copia impresa y no afectará a los derechos de propiedad intelectual del fabricante de la maquinaria parcialmente completada.

Vi ätar oss att vidarebefordra relevant information om maskindelarna vid en motiverad förfrågan från nationella myndigheter. Informationen ska erhållas i form av papperskopior och ska vara utan men för maskindelstillverkarens immateriella rättigheter.

2 SPECIFICATIONS

<p>Partly completed machinery must not be put into service until the final machinery into which it is to be incorporated has been declared in conformity with the provisions of Directive 2006/42/EC.</p> <p>Частично завършените машини не трябва да бъдат пускани в употреба, докато крайните машини, в които са вградени, не са приведени в съответствие с постановленията на директива 2006/42/EC.</p> <p>Částečně dokončené zařízení nesmí být uvedeno do provozu, dokud konečné zařízení, do kterého bylo uvedené zařízení namontováno, neodpovídá ustanovením Směrnice č. 2006/42/EC.</p> <p>Delvist fremstillede maskiner må ikke indsættes i driften, før den endelige maskine, som den skal inkorporeres i, er blevet erklæret i overensstemmelse med bestemmelserne i Direktiv 2006/42/EF.</p> <p>Gedeeltelijk voltooidde machinerie mag niet in dienst worden genomen, totdat er voor de definitieve machinerie, waarvan gedeeltelijk voltooidde machinerie onderdeel uitmaakt, een conformiteitsverklaring is ontvangen onder de voorwaarden van Richtlijn 2006/42/EG.</p> <p>Osaliselt komplekteeritud masinat ei tohi kasutusele võtta enne, kui lõplikult komplekteeritud masin, millega see ühendatakse, on tunnustatud direktiivi 2006/42/EÜ sätetele vastavaks.</p> <p>Osittain koottua laitteistoa ei saa ottaa käyttöön, ennen kuin lopullinen laiteisto, johon se asennetaan, on vakuutettu direktiivin 2006/42/EY säännösten mukaiseksi.</p> <p>La quasi-machine ne doit pas être mise en service avant que la machine finale dans laquelle elle doit être incorporée n'ait été déclarée conforme aux dispositions de la directive 2006/42/CE</p> <p>Die teilgefertigte Vorrichtung darf erst in Betrieb genommen werden, wenn die Konformität der Maschine, in die sie eingebaut wird, entsprechend den Bestimmungen der Richtlinie 2006/42/EG erklärt worden ist.</p> <p>Θα πρέπει να εκτελεστεί σέρβις στο ημιτελές μηχάνημα μέχρι το τελικό μηχάνημα στο οποίο θα ενσωματωθεί να έχει τη δήλωση συμμόρφωσης, σύμφωνα με τις διατάξεις της Οδηγίας 2006/42/ΕΚ.</p> <p>A részlegesen megépített gépet tilos üzembe helyezni mindaddig, amíg a 2006/42/EK irányelv rendelkezéseivel összhangban a részlegesen megépített gépet be nem építik a végleges változatba, és erről nem nyilatkoznak.</p> <p>La quasi-macchina non deve essere messa in servizio finché la macchina finale in cui deve essere incorporata non è stata dichiarata conforme, nel caso, alle disposizioni della Direttiva 2006/42/CE.</p> <p>Dajšji pabeigti iekārtu nedrīkst nodot ekspluatācijā, līdz galīgā iekārtai, kurā tā ir jāiebūvē, ir deklarēta atbilstoši direktīvas Nr. 2006/42/EK noteikumiem.</p> <p>Dalimai užbaigto mehanizmo negalima paleisti kol kiti mehanizmai, kurie dar bus prijungti, nebus patvirtinti kaip atitinkantys 2006/42/EC Direktivos reikalavimus.</p> <p>Il-makkinarju li jkun parzjalment lest ma g handux jibda jiffadedd sakemm il-makkinarju finali li fi ikun se ji gi inkorporat ikun ġie ddkjarat konformi mad-dispożizzjonijiet tad-Direttiva 2006/42/KE.</p> <p>Urządzenia częściowo ukończonego nie wolno użytkować aż do orzeczenia zgodności urządzenia w postaci kompletnej z wymaganiami dyrektywy 2006/42/WE.</p> <p>O equipamento parcial não poderá entrar em funcionamento antes do mecanismo final no qual vai ser incorporado ser declarado como estando em conformidade com as condições da Directiva 2006/42/CE.</p> <p>Echipamentul finalizat parțial nu trebuie pus în funcțiune până ce echipamentul final în care va fi încorporat nu este declarat ca fiind conform cu prevederile Directivei 2006/42/CE.</p> <p>Podzostava strojného zariadenia nesmie byť uvedená do prevádzky, pokiaľ finálne strojnè zariadenie, ktorého sa stane súčasťou, nebude vyhlásené ako zhodné s ustanoveniami smernice 2006/42/ES.</p> <p>Delno dokončaná stroja ni dovoljeno dati v obratovanje, dokler se dokončani stroj, v katerega se vgradi delno dokončani stroj, ne potrdi kot skladen z določbami Direktive 2006/42/ES.</p> <p>La maqinaria parcialmente completada no debe ponerse en servicio hasta que la maqinaria final a la que debe incorporarse cumpla con las provisiones de la Directiva 2006/42/CE.</p> <p>Maskindelarna får ej tas i bruk förrän maskinen som delen tillhör har deklarerats som överensstämmande med föreskrifterna i direktivet 2006/42/EG.</p>	<p>These accessories have been designed to be fitted to the Jacobsen Greens King IV mowers.</p>
<p>The place and date of the declaration • Место и дата на декларацията • Miesto a datum prohlášení • Sted og dato for erklæringen • Plaats en datum van de verklaring • Deklaratsiooni väljastamise koht ja kuupäev • Vakuutuskesen paikka ja päivämäärä • Lieu et date de la déclaration • Ort und Datum der Erklärung • Τόπος και ημερομηνία δήλωσης • A nyilatkozat kelte (hely és idő) • Luogo e data della dichiarazione • Deklarācijas vieta un datums • Deklaracijos vieta ir data • Il-post u l-data tad-dikjarazzjoni • Miejsce i data wystawienia deklaracji • Local e data da declaração • Locul și data declarației • Miesto a dátum vyhlásenia • Kraj in datum izjave • Lugar y fecha de la declaración • Plats och datum för deklarationen</p>	<p>Jacobsen, A Textron Company 11524 Wilmar Blvd. Charlotte, NC 28273, USA Sept 1st, 2012</p>
<p>Signature of the person empowered to draw up the declaration on behalf of the manufacturer, holds the technical documentation and is authorised to compile the technical file, and who is established in the Community.</p> <p>Подпис на човека, упълномощен да състави декларацията от името на производителя, който поддържа техническата документация и е оторизиран да изготви техническия файл и е регистриран в общността.</p> <p>Podpis osoby oprávněné sestavit prohlášení jménem výrobce, držet technickou dokumentaci a osoby oprávněné sestavit technické soubory a založené v rámci Evropského společenství.</p> <p>Underskrift af personen, der har fuldmagt til at udarbejde erklæringen på vegne af producenten, der er indehaver af dokumentationen og er bemyndiget til at udarbejde den tekniske journal, og som er baseret i nærområdet.</p> <p>Handtekening van de persoon die bevoegd is de verklaring namens de fabrikant te tekenen, de technische documentatie bewaart en bevoegd is om het technische bestand samen te stellen, en die is gevestigd in het Woongebied.</p> <p>Ühenduse registreeritud isiku allkiri, kes on volitatud tootja nimel deklaratsiooni koostama, kes omab tehnilist dokumentatsiooni ja kellel on õigus koostada tehniline toimik.</p> <p>Sen henklön allekirjoitus, jolla on valmistajan valtuutus vakuutuksen laatintaan, jolla on hallussaan tekniset asiakirjat, joka on valtuutettu laatimaan tekniset asiakirjat ja joka on sijoittautunut yhteisöön.</p> <p>Signature de la personne habilitée à rédiger la déclaration au nom du fabricant, à détenir la documentation technique, à compiler les fichiers techniques et qui est implantée dans la Communauté.</p> <p>Unterschrift der Person, die berechtigt ist, die Erklärung im Namen des Herstellers abzugeben, die die technischen Unterlagen aufbewahrt und berechtigt ist, die technischen Unterlagen zusammenzustellen, und die in der Gemeinschaft niedergelassen ist.</p> <p>Υπογραφή στόμου εξουσιοδοτημένου για την σύνταξη της δήλωσης εκ μέρους του κατασκευαστή, ο οποίος κατέχει την τεχνική έκθεση και έχει την εξουσιοδότηση να ταξινομήσει τον τεχνικό φάκελο και ο οποίος είναι διαρισμένος στην Κοινότητα.</p> <p>A gyártó nevében meghatalmazott személy, akinek jogában áll módosítani a nyilatkozatot, a műszaki dokumentációt őrizi, engedéllyel rendelkezik a műszaki fájllal összeállításához, és aki a közösségben letelepedett személy.</p> <p>Firma della persona autorizzata a redigere la dichiarazione a nome del fabbricante, in possesso Della documentazione tecnica ed autorizzata a costituire il fascicolo tecnico, che deve essere stabilita nella Comunità.</p> <p>Tās personas paraksts, kura ir pilnvarota deklarācijas sastādīšanai ražotāja vārdā, kurai ir tehniskā dokumentācija, kura ir pilnvarota sagatavot tehnisko reģistru un kura ir apstiprināta Kopienā.</p> <p>Asmuo, kuris yra gana žinomas, kuriam gamintojas suteikė įgaliojimus sudaryti šią deklaraciją, ir kuris ja pasirašė, turi visa techninę informaciją ir yra įgalotas sudaryti techninės informacijos dokumentą.</p> <p>Il-firma tal-persuna awtorizzata li tfassal id-dikjarazzjoni f'isem il-fabrikant, għandha d-dokumentazzjoni teknika u hija awtorizzata li tikkompila l-fajl tekniku u li hija stabbilita fil-Komunità.</p> <p>Podpis osoby upoważnionej do sporządzenia deklaracji w imieniu producenta, przechowującej dokumentację techniczną, upoważniona do stworzenia dokumentacji technicznej oraz wyznaczony ds. wspólnotowy.</p> <p>Assinatura da pessoa com poderes para emitir a declaração em nome do fabricante, que possui a documentação técnica, que está autorizada a compilar o processo técnico e que está estabelecida na Comunidade.</p> <p>Semnatūra persoanei împuternicite să elaboreze declarația în numele producătorului, care detine documentația tehnică, este autorizată să compileze dosarul tehnic și este stabilită în Comunitate.</p> <p>Podpis osoby poverenej vystavení vyhlásenia v mene výrobcu, ktorá má technickú dokumentáciu a je oprávnená spracovať technické podklady a ktorá je umiestnená v Spoločenstve.</p> <p>Podpis osebe, pooblašene za izdelavo izjave v imenu proizvajalca, ki ima tehnično dokumentacijo in lahko sestavlja spis tehnične dokumentacije, ter ima sedež v Skupnosti.</p> <p>Firma de la persona responsable de la declaración en nombre del fabricante, que posee la documentación técnica y está autorizada para recopilar el archivo técnico y que está establecido en la Comunidad.</p> <p>Undertecknas av den som bemyndigad att upprätta deklarationen å tillverkarens vägnar, innehar den tekniska dokumentationen och är bemyndigad att sammanställa den tekniska informationen och som är etablerad i gemenskapen.</p>	<p>2006/42/EC Annex II 1.A.2</p> <p>Tim Lansdell Technical Director Ransomes Jacobsen Limited West Road, Ransomes Europark, Ipswich, IP3 9TT, England</p> <p>2006/42/EC Annex II 1.A.10</p>  <p>Vasant Godhalekar VP of Engineering January 31st, 2011 Jacobsen, A Textron Company 11524 Wilmar Blvd, Charlotte, NC 28273, USA</p>
<p>Certificate Number • Номер на сертификата • Číslo osvědčení • Certifikatnummer • Certificaatnummer • Sertifikaadi number • Hyväksyntänumero • Número de certificar • Bescheinigungsnummer • Αριθμός Πιστοποιητικού • Hitelesítési szám • Numero del certificato • Sertifikata numus • Sertifikato numeris • Numnu tač-Certifikat • Numer certyfikatu • Número do Certificado • Număr certificat • Číslo osvedčenia • Številka certifikata • Número de certificado • Certifikatsnummer</p>	<p>4258370 Rev A</p>

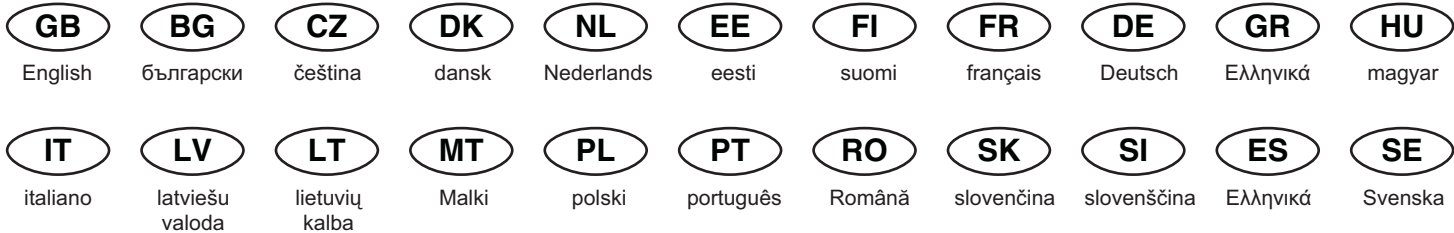

3.1 FRONT ROLLER AND ACCESSORIES

The front roller is not included with the reel assembly and must be ordered separately. Check with your dealer for front rollers that are available for your unit. Follow installation instructions included with the front roller.

Other accessories may also be available for your reel such as Turf Groomer®, roller scrapers, and roller brushes. Install these accessories before installing reels.

Follow instructions included in your mower's manuals and/or Turf Groomer's Instruction Sheet for adjusting the reel to bedknife and height of cut.

3.2 REEL MOTOR

1. Remove hardware from each of the mounting studs on the housing and remove cover plate (Not shown).
2. Move cutting unit to corresponding location and assemble motor to housing with hardware removed in Step 1. Gasket (A) must be between motor and housing.

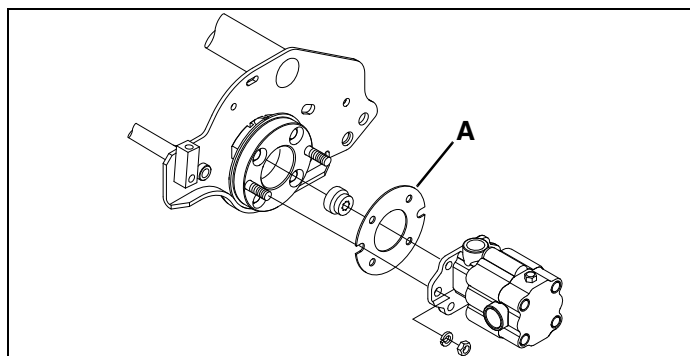

Figure 3A

3.3 TORSION SPRINGS

Torsion spring components are included with the mower.

1. Slide one clamp (F) over each lift arm and secure with 5/16-18 x 1-1/4" carriage bolt and 5/16-18 locknut (G and E). Do not tighten.
2. Slide the right (J) and left (H) torsion spring over their respective lift arms. Insert end of springs between clamp ends.
3. Slide swivel housing (B) onto the lift arm and secure housing with pin (C). Hook ends of torsion spring over pin (C).

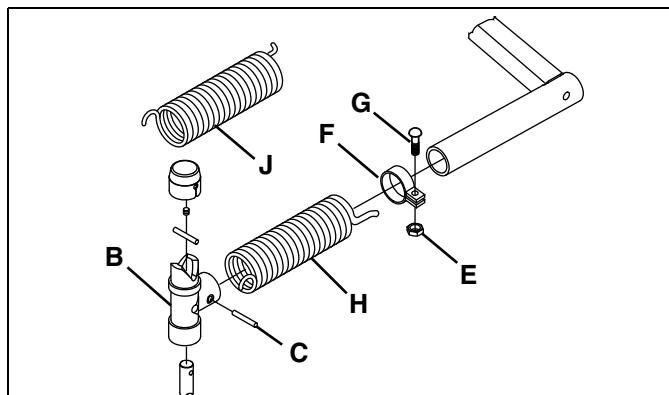

Figure 3B

3.4 ANTI-SWAY SPRINGS

Anti-Sway spring components are included with the mower and assembled to center reel only.

1. Assemble one 1/2-13 hex jam nut (L) onto rod (M) then secure the rod to the bottom rear of frame with 1/2" lockwasher and 1/2-13 jam nut (K).
2. Assemble anti-sway spring to adjusting rod and then the rear lift yoke.
3. Adjust anti-sway spring.

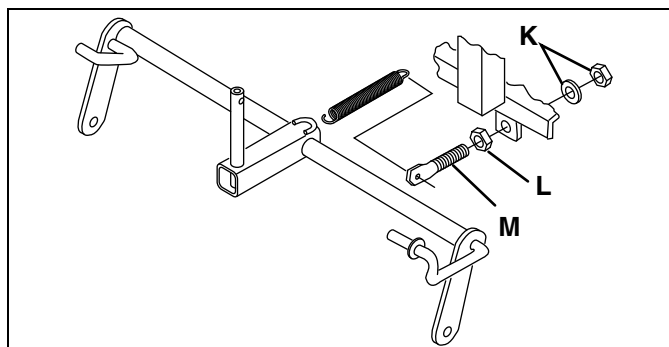

Figure 3C

4 ADJUSTMENTS

4.1 GENERAL

WARNING

Before you clean, adjust, or repair this equipment, disengage all drives, lower implements to the ground, turn system power off, remove key from ignition switch, and disconnect battery pack(s) to prevent injuries

Make sure the mower is parked on a solid and level surface. Never work on a mower that is supported only by the jack. Always use jack stands.

1. Adjustments and maintenance should always be performed by a qualified technician. If proper adjustment cannot be made, contact an authorized Jacobsen Dealer.

2. Replace, do not adjust, worn or damaged components.
3. Long hair, jewelry or loose fitting clothing may get tangled in moving parts.

CAUTION

Be careful to prevent entrapment of the hands and fingers between moving and fixed components of the machine.

4. Do not change speed limit settings or overspeed the drive motors.

4.2 BEDKNIFE-TO-REEL (Pre-adjustment Check)

1. Check the reel bearings for end play or radial play. There should be no end play or radial play. See Section 4.10.

CAUTION

To prevent personal injury and damage to the cutting edges, wear gloves and handle the reel and bedknife with extreme care.

2. Inspect the reel blades and bedknife to insure good sharp edges without bends or nicks.
 - a. The leading edge of the reel blades must be sharp, free of burrs and show no signs of rounding off.
 - b. The bedknife and bedknife backing must be securely tightened. The bedknife must be straight and sharp.
 - c. A flat surface of at least 1/32 in. (0.8 mm) minimum must be maintained on the front face of the bedknife. Use a standard flat file to dress the bedknife.
3. If wear or damage is beyond the point where the reel or bedknife can be corrected by the lapping process, they must be reground.
4. Proper reel-to-bedknife adjustment is critical. A gap of 0.001 to 0.003" (0.025 to 0.076 mm) must be maintained across the entire length of the reel and bedknife.
5. The reel must be parallel to the bedknife. An improperly adjusted reel will lose its sharp edges prematurely and may result in serious damage to the reel and bedknife.
6. Grass conditions will also affect the adjustment.

- a. Dry, sparse conditions will require a wider gap to prevent heat buildup and damage to the reel and bedknife.
- b. High quality grass with a good moisture content requires a closer gap (near zero).

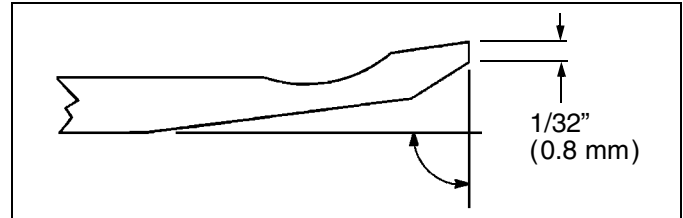

Figure 4A

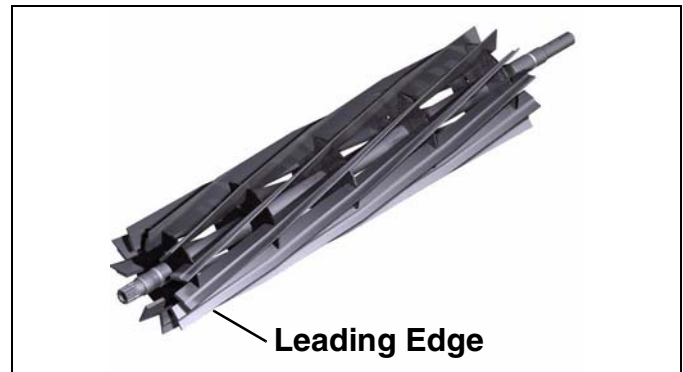

Figure 4B

4.3 BEDKNIFE ADJUSTMENT

1. Read Section 4.1 before making the adjustment.
2. Start adjustment at the leading end of the reel, followed by the trailing end. *The leading end of the reel blades is that end which passes over the bedknife first during normal reel rotation.*
3. Use adjusters (**B** and **C**), to adjust gap. Rotate adjusters (Clockwise) to close gap. Each click of the adjuster moves the bedknife 0.001" (0.025 mm) closer to the reel.
 - a. Slide a feeler gauge or shim stock 0.001" - 0.003" (0.025 - 0.075 mm) between the reel blade and the bedknife. Do not turn the reel.
 - b. Adjust the trailing end of the reel to the same gap in a similar manner then recheck the adjustment at the leading end.
 - c. When the reel is properly adjusted to the bedknife, the reel will spin freely and you should be able to cut a piece of newspaper, along the full length of the reel, when the paper is held at 90° to the bedknife.

NOTICE

Avoid excessive tightening or serious damage may result to bedknife and reel blades. Reels must turn freely.

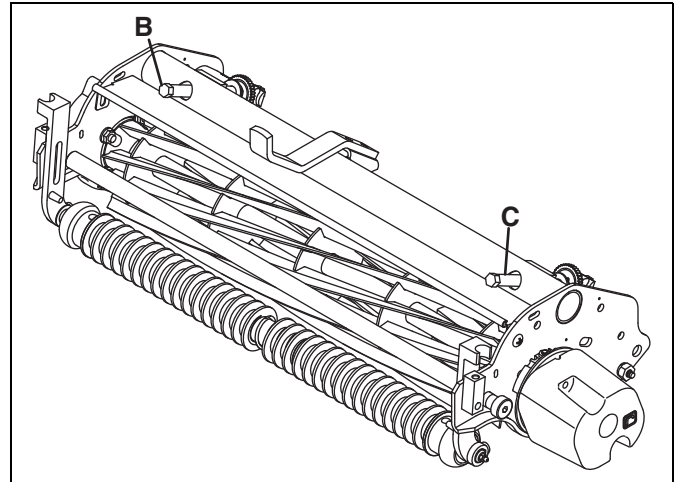

Figure 4C

4.4 CUTTING HEIGHT

Note: Always make the reel to bedknife adjustment before adjusting height of cut. (Sections 4.2 and 4.3).

1. Set desired cutting height on the gauge (**E**).
 - a. Measure distance between the underside of screw head and gauge block surface (**F**).
 - b. Adjust screw (**H**) to obtain desired height then tighten the wing nut.
2. Loosen the nuts on the front roller brackets (**G**) just enough to allow the adjuster knob (**K**) to raise or lower the front roller.
3. Place gauge (**E**) across bottom of front and rear rollers near one end of roller.
4. Slide the head of gauge screw (**H**) over the bedknife (**L**) and adjust the knob (**K**) to close the gap between the screw head and bedknife. Then tighten locknut (**G**).
5. Repeat Steps 4 and 5 on opposite end. Complete adjustment to one end before adjusting opposite end.
6. Tighten nuts (**G**) and recheck each end.

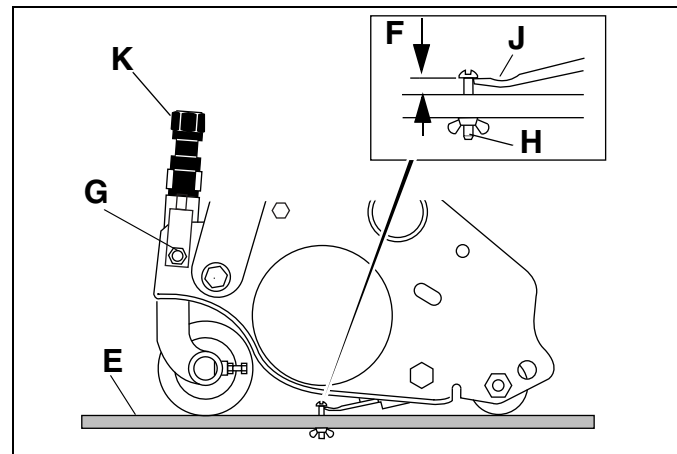

Figure 4D

4 ADJUSTMENTS

4.5 REEL BEARING

Any radial play or excessive end play indicates bad bearings, a weak tension spring or a backed off nut.

1. Check bearing housing mounting hardware. Tighten or replace components as required. Carefully clean threads with degreaser.
2. Apply a medium strength grade of Loctite to nut (**P**), then thread nut onto the reel shaft until the nut is 1-27/32" (46 mm) from the end of the reel shaft.
3. Fill reel bearing housings with NLGI - Grade O grease after adjusting spring.

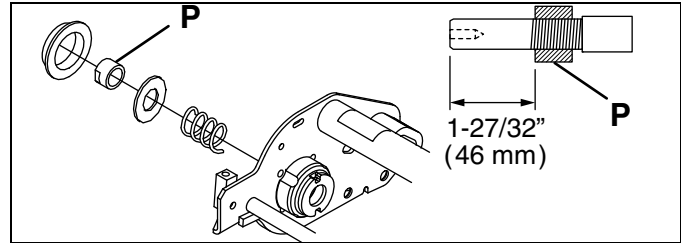

Figure 4E

4.6 BEDKNIFE ADJUSTER SPRING

For proper operation, bedknife adjuster spring should be compressed to a dimension of 1-7/16 - 1-1/2 in. (36.5-38 mm).

To adjust spring compression, loosen or tighten nut (**R**) to obtain a distance of 1-7/16 - 1-1/2 in. (36.5-38 mm).

After adjusting spring, check reel to bedknife adjustment.

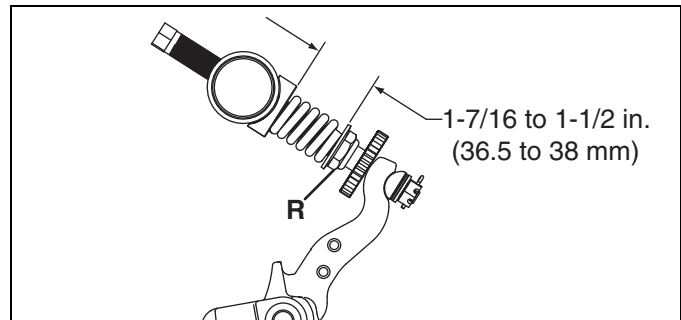

Figure 4F

4.7 BEDKNIFE ADJUSTER TENSION

NOTICE

Overtightening slotted nut (**S**) will make bedknife adjuster rod (**T**) difficult to adjust.

Remove cotter pin (**U**) and fully loosen, then tighten slotted nut (**S**) to remove clearance (no end play) between components. Continue to tighten nut until next slot in nut aligns with hole in bedknife adjuster rod (**T**). Install new cotter pin.

Check torque required to rotate adjuster rod (**T**). Maximum torque should be 24 in. lb. (2 ft. lb.) (2.7 Nm).

After adjusting nut, check reel to bedknife adjustment.

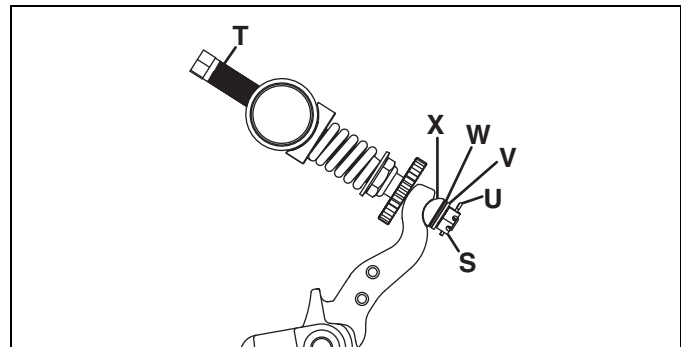

Figure 4G

4.8 GRINDING BEDKNIFE

Bedknife can be lowered out of the reel for grinding without completely removing the bedknife assembly.

1. Remove cotter pin (**U**), slotted nut (**S**), bellville washer (**V**), shim washer (**W-If required**), and half trunnion (**X**). See Figure 4G
4. Press down on adjuster end of rod (**T**) to rotate other end of the adjuster out of the bedknife finger.

5. Rotate bedknife backing to access the reel and bedknife for grinding.
6. After grinding, assemble bedknife using reverse order of removal. Check adjustment of bedknife adjuster tension (**Section 4.7**), and reel to bedknife adjustment (**Section 4.3**).

4.9 ANTISWAY SPRING

1. The antisway spring (C) should be tight but not under stress.
2. Loosen both nuts on the adjusting rod then adjust the rear nut as necessary.
3. When properly adjusted, tighten nuts against bracket.

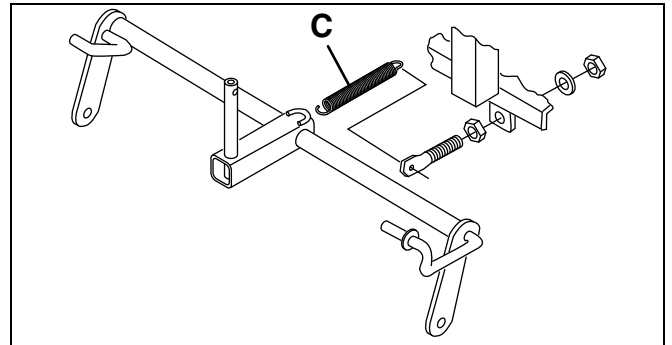

Figure 4H

4.10 LEVELING PROCEDURE

1. Lower the implements until they are about 1/4 in. (6.35 mm) above the ground. If they are not level with the ground, adjust torsion spring (Z).

WARNING

The torsion spring is under extreme tension and will tend to uncoil very rapidly if the clamp is loosened. To prevent being cut by clamp or spring, unwind spring by tapping on clamp while slowly loosening nut.

2. Carefully loosen spring mounting clamp and slowly turn clamp until implement is level. Tighten clamp securely.

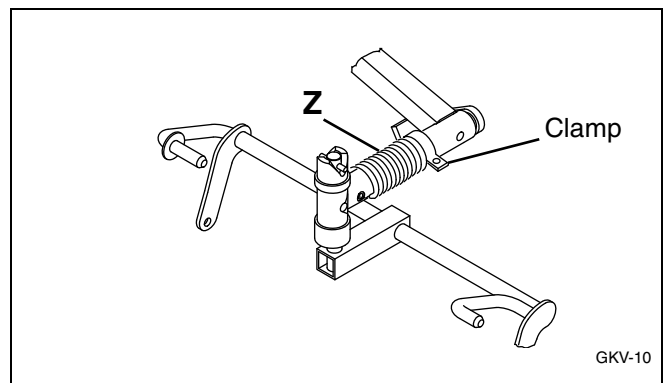

Figure 4J

4 ADJUSTMENTS





4.11 TORQUE SPECIFICATION

NOTICE



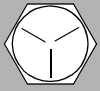

All torque values included in these charts are approximate and are for reference only. Use of these torque values is at your sole risk. Jacobsen is not responsible for any loss, claim, or damage arising from the use of these charts. **Extreme caution should always be used when using any torque value.**

Jacobsen uses Grade 5 Plated bolts as standard, unless otherwise noted. For tightening plated bolts, use the value given for lubricated.

AMERICAN NATIONAL STANDARD FASTENERS

SIZE	UNITS					SIZE	UNITS				
		GRADE 5		GRADE 8				GRADE 5		GRADE 8	
		Lubricated	Dry	Lubricated	Dry			Lubricated	Dry	Lubricated	Dry
#6-32	in-lb (Nm)	–	20 (2.3)	–	–	7/16-14	ft-lb (Nm)	37 (50.1)	50 (67.8)	53 (71.8)	70 (94.9)
#8-32	in-lb (Nm)	–	24 (2.7)	–	30 (3.4)	7/16-20	ft-lb (Nm)	42 (56.9)	55 (74.6)	59 (80.0)	78 (105)
#10-24	in-lb (Nm)	–	35 (4.0)	–	45 (5.1)	1/2-13	ft-lb (Nm)	57 (77.2)	75 (101)	80 (108)	107 (145)
#10-32	in-lb (Nm)	–	40 (4.5)	–	50 (5.7)	1/2-20	ft-lb (Nm)	64 (86.7)	85 (115)	90 (122)	120 (162)
#12-24	in-lb (Nm)	–	50 (5.7)	–	65 (7.3)	9/16-12	ft-lb (Nm)	82 (111)	109 (148)	115 (156)	154 (209)
1/4-20	in-lb (Nm)	75 (8.4)	100 (11.3)	107 (12.1)	143 (16.1)	9/16-18	ft-lb (Nm)	92 (124)	122 (165)	129 (174)	172 (233)
1/4-28	in-lb (Nm)	85 (9.6)	115 (13.0)	120 (13.5)	163 (18.4)	5/8-11	ft-lb (Nm)	113 (153)	151 (204)	159 (215)	211 (286)
5/16-18	in-lb (Nm)	157 (17.7)	210 (23.7)	220 (24.8)	305 (34.4)	5/8-18	ft-lb (Nm)	128 (173)	170 (230)	180 (244)	240 (325)
5/16-24	in-lb (Nm)	173 (19.5)	230 (26.0)	245 (27.6)	325 (36.7)	3/4-10	ft-lb (Nm)	200 (271)	266 (360)	282 (382)	376 (509)
3/8-16	ft-lb (Nm)	23 (31.1)	31 (42.0)	32 (43.3)	44 (59.6)	3/4-16	ft-lb (Nm)	223 (302)	298 404	315 (427)	420 (569)
3/8-24	ft-lb (Nm)	26 (35.2)	35 (47.4)	37 (50.1)	50 (67.8)	7/8-14	ft-lb (Nm)	355 (481)	473 (641)	500 (678)	668 (905)

METRIC FASTENERS

SIZE	UNITS									Non Critical Fasteners into Aluminum
		4.6		8.8		10.9		12.9		
		Lubricated	Dry	Lubricated	Dry	Lubricated	Dry	Lubricated	Dry	
M4	Nm (in-lb)	–	–	–	–	–	–	3.83 (34)	5.11 (45)	2.0 (18)
M5	Nm (in-lb)	1.80 (16)	2.40 (21)	4.63 (41)	6.18 (54)	6.63 (59)	8.84 (78)	7.75 (68)	10.3 (910)	4.0 (35)
M6	Nm (in-lb)	3.05 (27)	4.07 (36)	7.87 (69)	10.5 (93)	11.3 (102)	15.0 (133)	13.2 (117)	17.6 (156)	6.8 (60)
M8	Nm (in-lb)	7.41 (65)	9.98 (88)	19.1 (69)	25.5 (226)	27.3 (241)	36.5 (323)	32.0 (283)	42.6 (377)	17.0 (150)
M10	Nm (ft-lb)	14.7 (11)	19.6 (14)	37.8 (29)	50.5 (37)	54.1 (40)	72.2 (53)	63.3 (46)	84.4 (62)	33.9 (25)
M12	Nm (ft-lb)	25.6 (19)	34.1 (25)	66.0 (48)	88.0 (65)	94.5 (70)	125 (92)	110 (81)	147 (108)	61.0 (45)
M14	Nm (ft-lb)	40.8 (30)	54.3 (40)	105 (77)	140 (103)	150 (110)	200 (147)	175 (129)	234 (172)	94.9 (70)

GREENS KING IV REEL

Serial No. All

6.1 Outer Reel

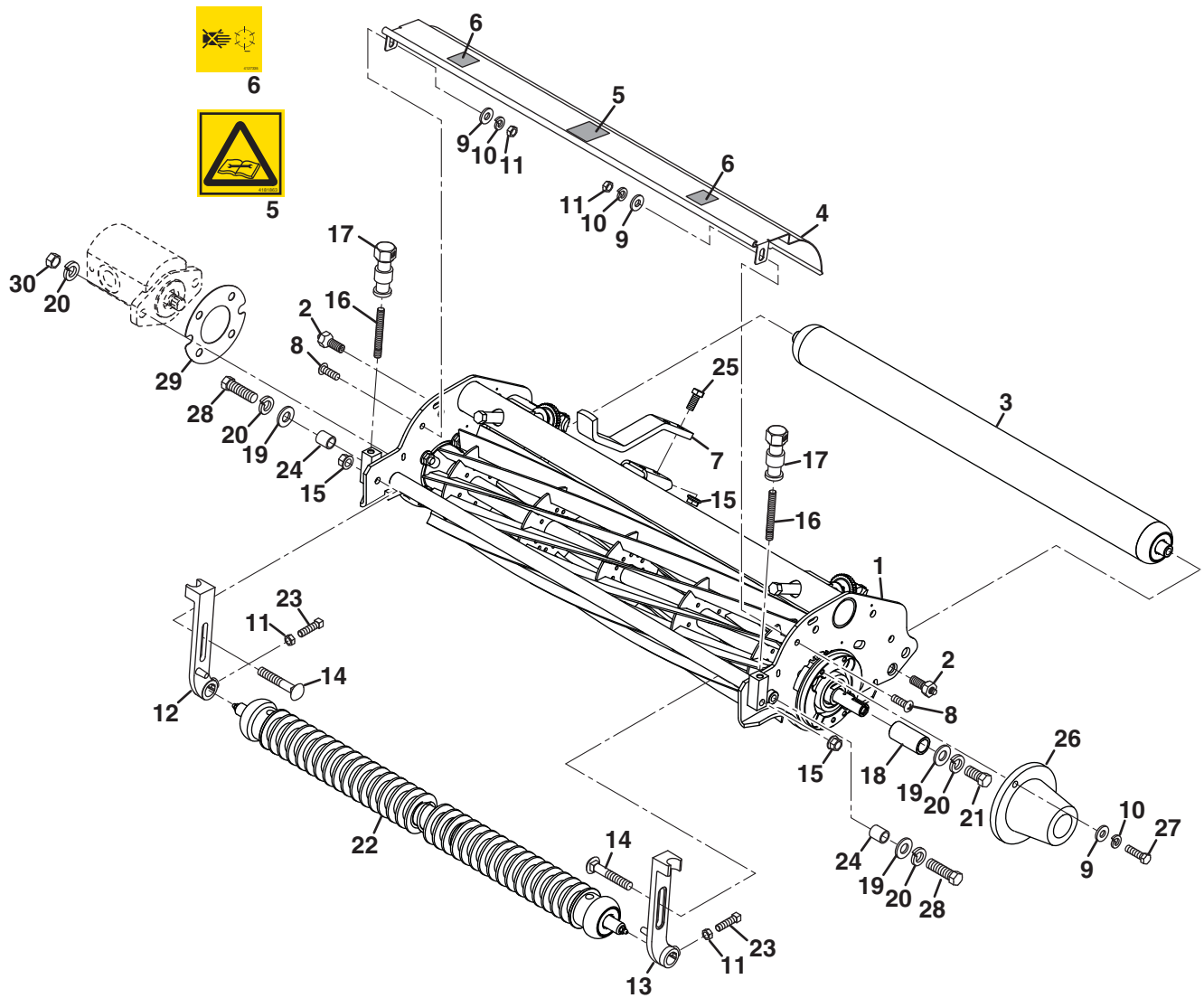

GREENS KING IV REEL

Item	Part No.	Qty.	Description	Serial Numbers/Notes
1	REF	1	Inner Reel	See 7.1
2	1002224	2	Zerk Bolt	
3	1004990	1	22" Rear Roller	See 8.1
4	2810043	1	Shield, Grass	
5	4181863	1	Decal, Read Manual for Service	
6	4127335	2	Decal, Danger	
7	3010293	1	Stop, Reel	
8	403782	2	Screw, 1/4-20 x 3/4" Truss Head	
9	453023	4	Flat Washer, 1/4	
10	446130	4	Lockwasher, 1/4 Heavy	
11	443102	4	Nut, 1/4-20 Hex	
12	3008438	1	Bracket, Right Side Front Roller	
13	3008439	1	Bracket, Left Side Front Roller	
14	441674	2	Carriage Bolt, 5/16-18 x 1-3/4"	
15	445795	4	Nut, 5/16-18 Spiralock Flange	
16	343616	2	Stud, Front Roller Adjuster	
17	3005692	2	Knob, Front Roller Adjuster	
18	367164	1	Spacer	
19	453011	3	Flat Washer, 3/8	
20	446142	3	Lockwasher, 3/8 Heavy	
21	400294	1	Screw, 3/8-24 x 1" Hex Head	
22	REF	1	Front Roller	Not included with reel.
23	352737	2	Set Screw, 1/4-20 x 7/8" Grade 8	
24	345510	2	Spacer, Lift Yoke	
25	400184	2	Screw, 5/16-18 x 3/4" Hex Head	
26	338675	1	Cover, Reel Shaft	
27	400104	2	Screw, 1/4-20 x 1/2" Hex Head	
28	400264	2	Screw, 3/8-16 x 1-1/4" Hex Head	
29	364901	1	Gasket, Motor	
30	443110	2	Nut, 3/8-16 Hex	

> Change from previous revision

GREENS KING IV REEL

7.1 Inner Reel

Serial No. All

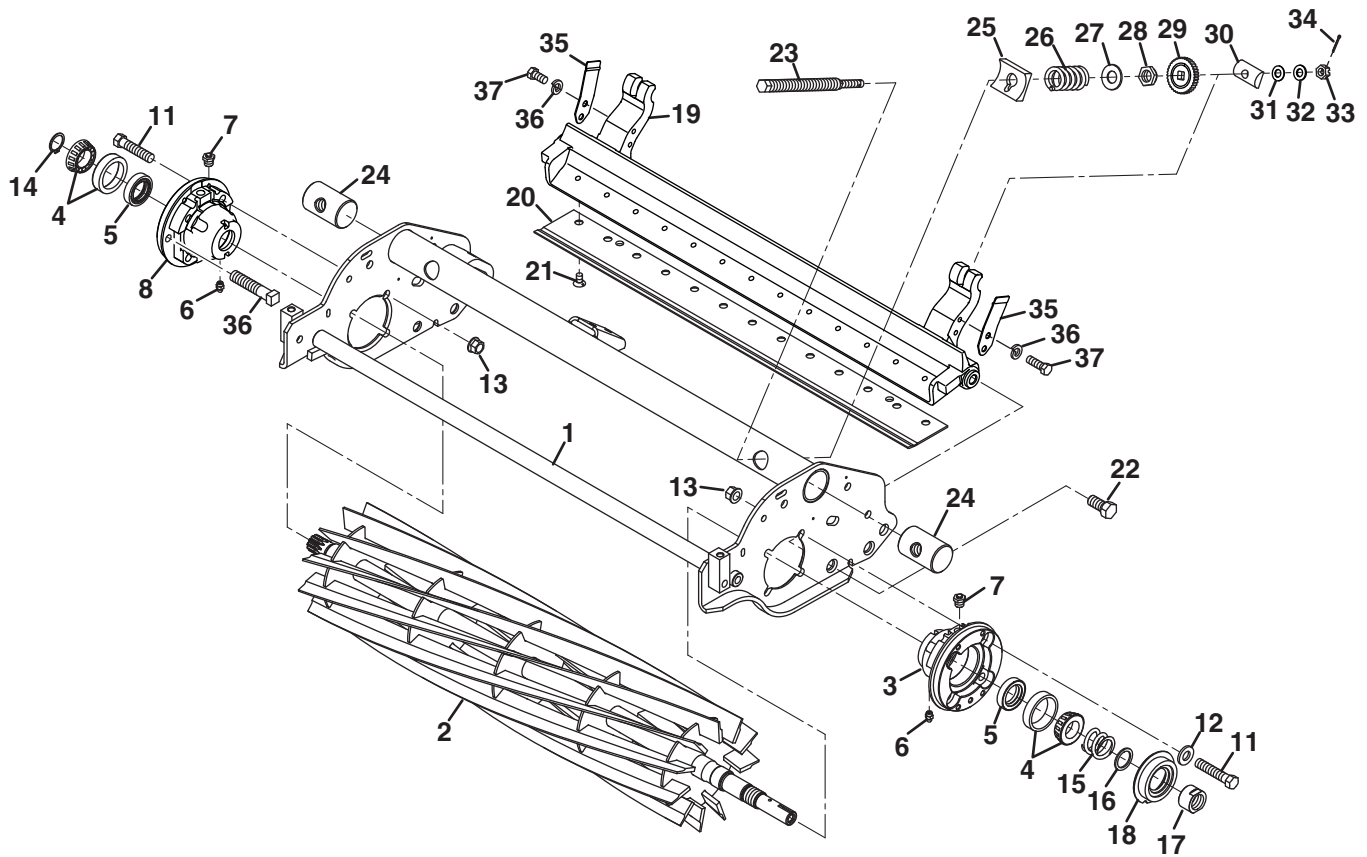

Standard Style Bedknives (Secured with screws)

Part Number	Description
▲ 5003150	22" Medium Section
503477	22" High Profile
◆ 503478	22" Low Profile
503479	22" Tournament
● 5002887	22" Super Tournament
4234900	22" Championship

- ▲ Standard Bedknife (7 Blade)
- ◆ Standard Bedknife (9 Blade)
- Standard Bedknife (11 and 15 Blade)

Optional MagKnife Bedknives

Part Number	Description
4131369	22" High Profile
4131001	22" Low Profile
4131370	22" Tournament
4131003	22" Super Tournament

GREENS KING IV REEL

Item	Part No.	Qty.	Description	Serial Numbers/Notes
1	4256225	1	22" Reel Frame	
2	5003053	1	Reel, 22" Left Hand 7 Blade	
2	5003044	1	Reel, 22" Right Hand 7 Blade	
2	5001099	1	Reel, 22" Left Hand 9 Blade	
2	5001100	1	Reel, 22" Right Hand 9 Blade	
2	5001101	1	Reel, 22" Left Hand 11 Blade	
2	5001102	1	Reel, 22" Right Hand 15 Blade	
2	4225505	1	Reel, 22" Left Hand 15 Blade	
2	4269791	1	Reel, 22" Right Hand 15 Blade	
3	1000480	1	Housing, Bearing	
4	500534	1	• Bearing, Cup and Cone	
5	336962	1	• Seal, Grease	
6	471214	1	• Grease Fitting	
7	471240	1	• Vent Fitting	
8	1002256	1	Housing, Bearing	Includes Items 4~7
9	400104	4	Screw, 1/4-20 x 1/2" Hex Head	
10	446130	4	Lockwasher, 1/4 Heavy	
11	400192	8	Screw, 5/16-18 x 1-1/2" Socket Head	
12	453009	4	Flat Washer, 5/16	
13	445795	8	Nut, 5/16-18 Spirallock Flange	
14	458013	1	Ring, Snap	
15	5002151	1	Spring, Compression	
16	304745	1	Washer, Reel Shaft	
17	364900	1	Nut, 3/4-16 Reel	
18	163892	1	Seal Assembly	
19	4255754	1	Backing, 22" Bedknife	
20	See Chart	1	Bedknife	
21	4252470	AR	Screw, Bedknife	Package of 100 Screws
22	315298	2	Bolt, 7/16-20 x 3/4" Wheel	
23	4256228	2	Rod, Bedknife Adjuster	
24	4256227	2	Trunnion, Internal	
25	4256229	2	Cradle, Tube Spring	
26	4256231	2	Spring, Compression	
27	400051	2	Washer, 1/2" Bellville	
28	400050	2	Nut, 1/2-20 Hex Jam Nylock	
29	4256233	2	Washer, Bedknife Adjustment	
30	4256232	2	Trunnion Half	
31	400052	2	Washer, 5/16 Bellville	
32	400065	AR	Washer, Shim	
33	400053	2	Nut, 5/16-24 Hex Slotted	
34	460008	2	Cotter Pin, 5/64 x 3/4"	
35	4256230	2	Spring, Detent	
36	441814	2	Screw, 5/16-18 x 1-3/4" Square Head	

> Change from previous revision

GREENS KING IV REEL

Serial No. All

8.1 Rear Roller

1004990

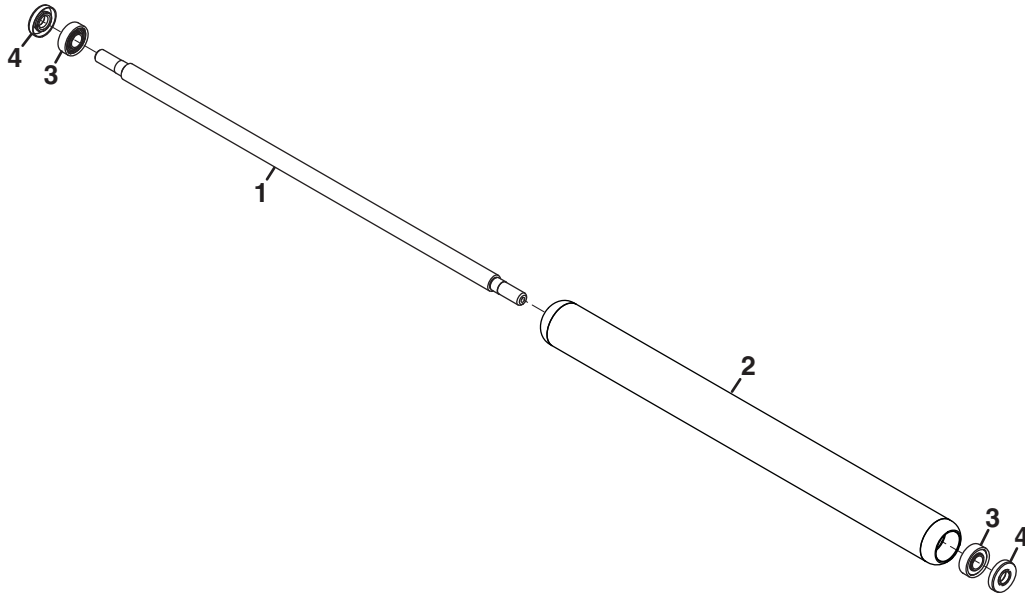

Item	Part No.	Qty.	Description	Serial Numbers/Notes
	1004990	1	22" Rear Roller	
1	3010422	1	• Shaft, 22" Roller	
2	5002814	1	• Tube, 22" Roller	
3	3010712	2	• Bearing, Ball	
4	3010286	2	• Seal	

> Change from previous revision

9.1 Machined Grooved Roller

68613 and 68614

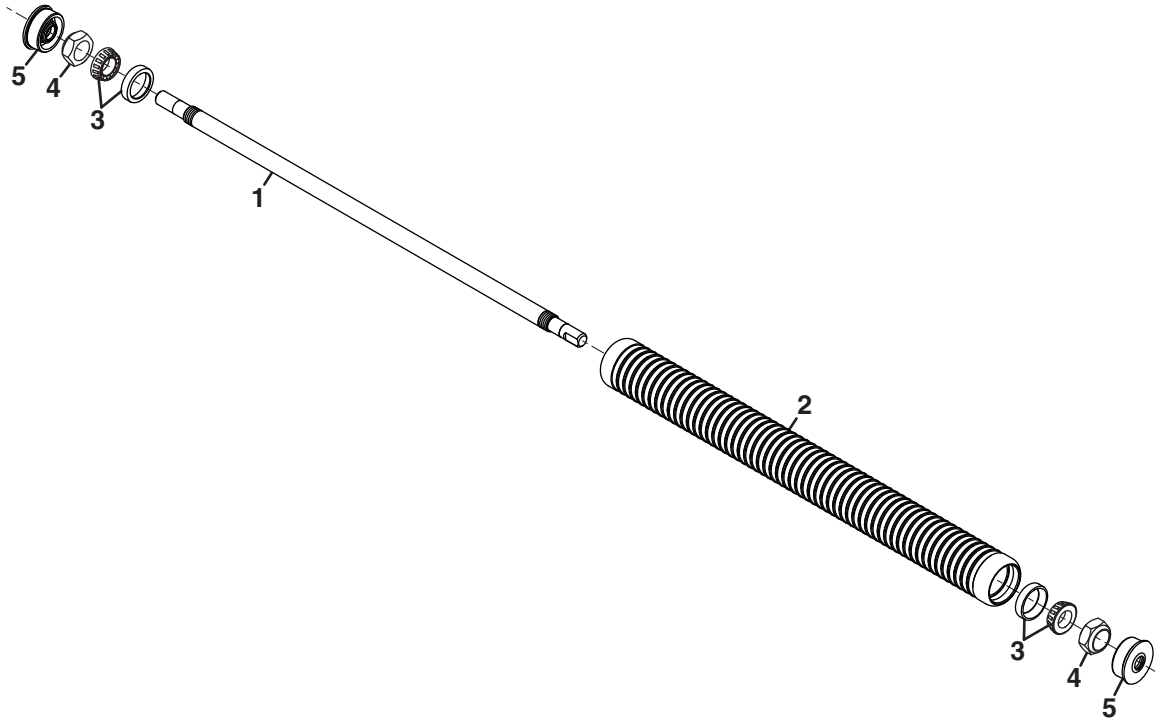

Item	Part No.	Qty.	Description	Serial Numbers/Notes
	68613	1	22" Machined Grooved Steel	
	68614	1	22" Machined Grooved Aluminum	
1	3009725	1	• Shaft, 22" Roller	
2	5002815	1	• Roller, 22" Grooved Steel	Used on 68613
2	3000394	1	• Roller, 22" Grooved Aluminum	Used on 68614
3	503378	2	• Bearing, Cup and Cone	
4	367029	2	• Locknut, 3/4-16	
5	3010210	2	• Adapter, Seal	

> Change from previous revision

10.1 Solid Front Roller

68530 and 68641

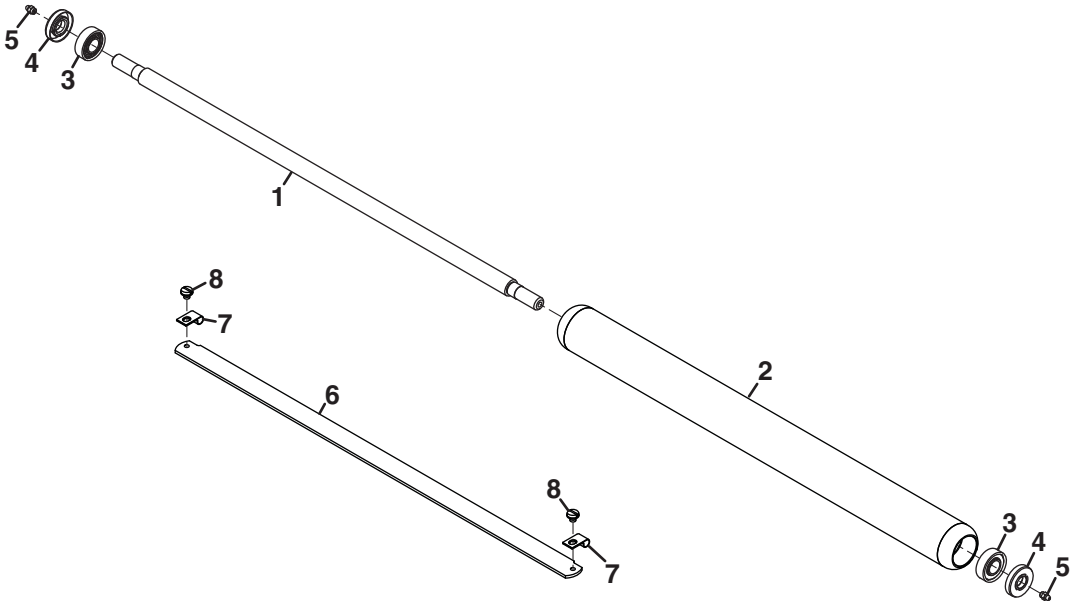

Item	Part No.	Qty.	Description	Serial Numbers/Notes
	1004991	1	22" Solid Front Roller (Light)	
	1004988	1	22" Solid Front Roller	
1	3010621	1	• Shaft, 22" Roller	
2	5002814	1	• Roller, 22" Solid (Light)	Used on 1004991
2	3007008	1	• Roller, 22" Solid	Used on 1004988
3	3010712	2	• Bearing, Ball	
4	3010286	2	• Seal	
5	471214	2	• Fitting, Grease	
	68530	1	22" Solid Front Roller with Scraper	Includes 1004991
	68641	1	22" Solid Front Roller with Scraper	Includes 1004988
6	2500022	1	• Scaper Assembly	
7	352214	2	• • Clip	
8	407586	2	• • 1/4-20 Pan Head Screw	

> Change from previous revision

11.1 22" Grooved Steel Disc Front Roller

68527

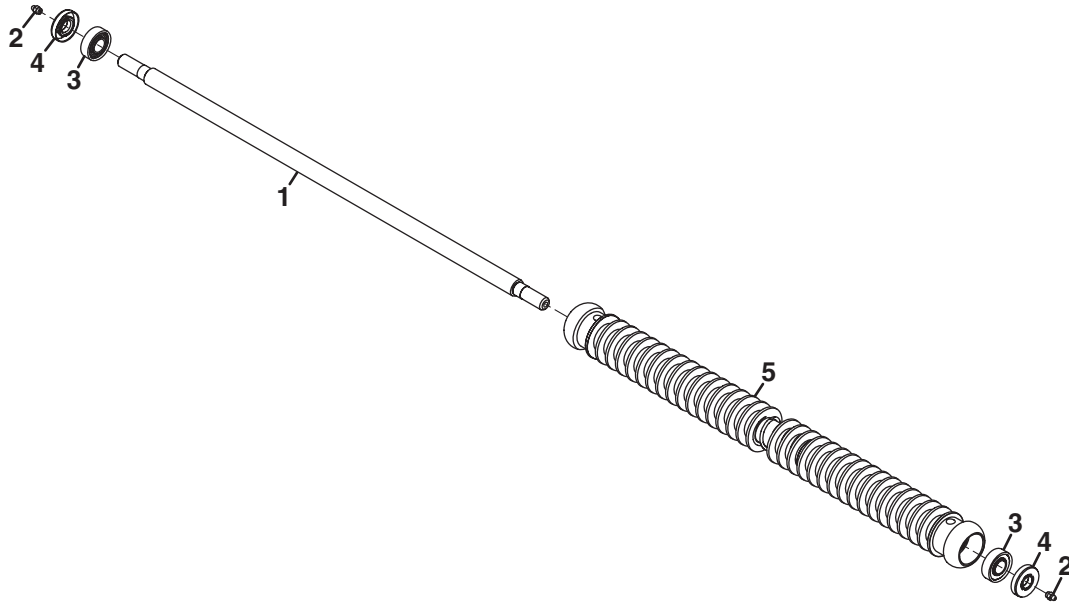

Item	Part No.	Qty.	Description	Serial Numbers/Notes
	68527	1	22" Front Roller	
1	3010621	1	• Shaft	
2	471214	2	• Grease Fitting	
3	3010712	2	• Bearing, Ball	
4	3010286	2	• Seal	
5	129806	1	• Grooved Roller	

> Change from previous revision

GREENS KING IV REEL

Serial No. All

12.1 22" Segmented Grooved Front Roller

68673

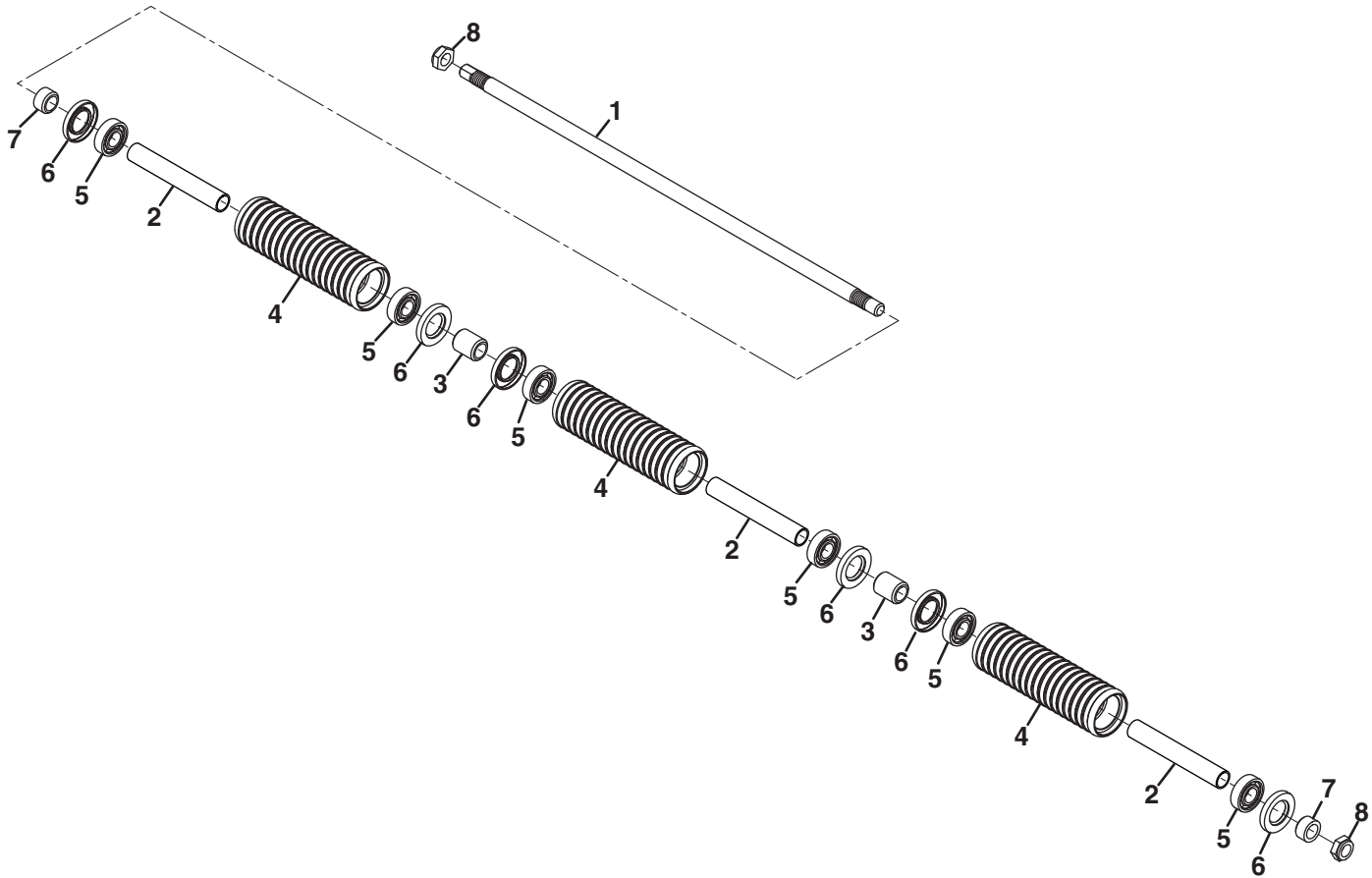

Item	Part No.	Qty.	Description	Serial Numbers/Notes
	68673	1	22" Segmented Grooved Front Roller	
1	2810708	1	• Shaft, Roller	
2	4130417	3	• Spacer, Bearing	
3	4130418	2	• Spacer, Bearing	
4	4130419	3	• Roller, Segmented Grooved	
5	366707	6	• Bearing, Ball	
6	338773	6	• Seal, Grease	
7	4130428	2	• Spacer, Bearing	
8	445801	2	• Nut, 5/8-18 Hex Jam Nylon Insert	

> Change from previous revision

This page intentionally Blank

> Change from previous revision

World Class Quality, Performance And Support

Equipment from Jacobsen is built to exacting standards ensured by ISO 9001 and ISO 14001 registration at all of our manufacturing locations.

A worldwide dealer network and factory trained technicians backed by Genuine Jacobsen Parts provide reliable, high-quality product support.



When Performance Matters.™

CUSHMAN JACOBSEN RANSOMES

1	Safety	
1.1	Operating Safety	4
1.2	Important Safety Notes	5
2	Specifications	
2.1	Product Identification	6
2.2	Cutting Units	6
2.3	Accessories & Support Literature	6
2.4	Declaration of Incorporation	7
3	Setup	
3.1	Front Roller and Accessories	9
3.2	Reel Motor	9
3.3	Torsion Springs	9
3.4	Anti-Sway Springs	9
4	Adjustments	
4.1	General.....	10
4.2	Bedknife-To-Reel	10
4.3	Bedknife Adjustment	11
4.4	Cutting Height	11
4.5	Reel Bearing	12
4.6	Bedknife Adjuster Spring	12
4.7	Bedknife Adjuster Tension	12
4.8	Grinding Bedknife	12
4.9	Antisway Spring	13
4.10	Leveling Procedure	13
4.11	Torque Specification	14
5	Notes	